

## HPM2.Z sets

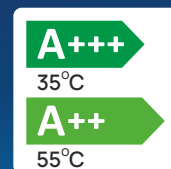

Integrated package consisting of **HPM02** heat pump and **HPMI2** indoor unit for installation in new and retrofit homes.



5 lat gwarancji

Heat pump packages  
monoblock type

### HPM2.Z-8

- HPM02-8 - heat pump
- HPMI2-8 - indoor unit



Heat pump packages  
monoblock type

### HPM2.Z-12

- HPM02-12 - heat pump
- HPMI2-12 - indoor unit



Heat pump packages  
monoblock type

### HPM2.Z-16/23

- HPM02-16/23 - heat pump
- HPMI2-16 - indoor unit



## Technical data

Product code	Set components	Maximum heating power (kW)*	Cop maximum*	Electricity efficiency class*	Max pressure level -Q2 / power factor sound power dB(A)*	Electric unit heating	Power supply	Rated current of the overcurrent circuit breaker	Minimum cross-sectional area of the supply cable
HPM2.Z-8	HPM02-8 HPMI2-8	8,2 (A+7/W35) 7,1 (A+2/W35) 5,8 (A-7/W35)	4,6 (A+7/W35) 4,01 (A+2/W35) 3,49 (A-7/W35)	A+++ (W35) A++ (W55)	52 z odległ. 1m / 60	6kW	400V 3N~ / 230 V~	3x16A / 40A	5x2,5mm <sup>2</sup> / 3x6mm <sup>2</sup>
HPM2.Z-12	HPM02-12 i HPMI2-12	12,5 (A+7/W35) 11,3 (A+2/W35) 9,2 (A-7/W35)	4,75 (A+7/W35) 3,94 (A+2/W35) 3,37 (A-7/W35)		55 z odległ. 1m / 63	6kW	400V 3N~ / 230 V~	3x25A / 50A	5x2,5mm <sup>2</sup> / 3x6mm <sup>2</sup>
HPM2.Z-16/23	HPM02-16/23 i HPMI2-16	23,0 (A+7/W35) 20,5 (A+2/W35) 17,1 (A-7/W35)	4,76 (A+7/W35) 4,02 (A+2/W35) 3,47 (A-7/W35)		56 z odległ. 1m / 64	9kW	400 V 3N~	3x32A	5x2,5mm <sup>2</sup>

HPM2.Z packages also include:  
- WE-019/01 storage tank sensor  
- 2 heating circuit sensors WE-019/05  
- WE-027 outdoor temperature sensor  
- room temperature sensor WE-033/02

\* HPM02 heat pump specifications

## Schematic diagram of the HPM2.V and HPM2.P package installation

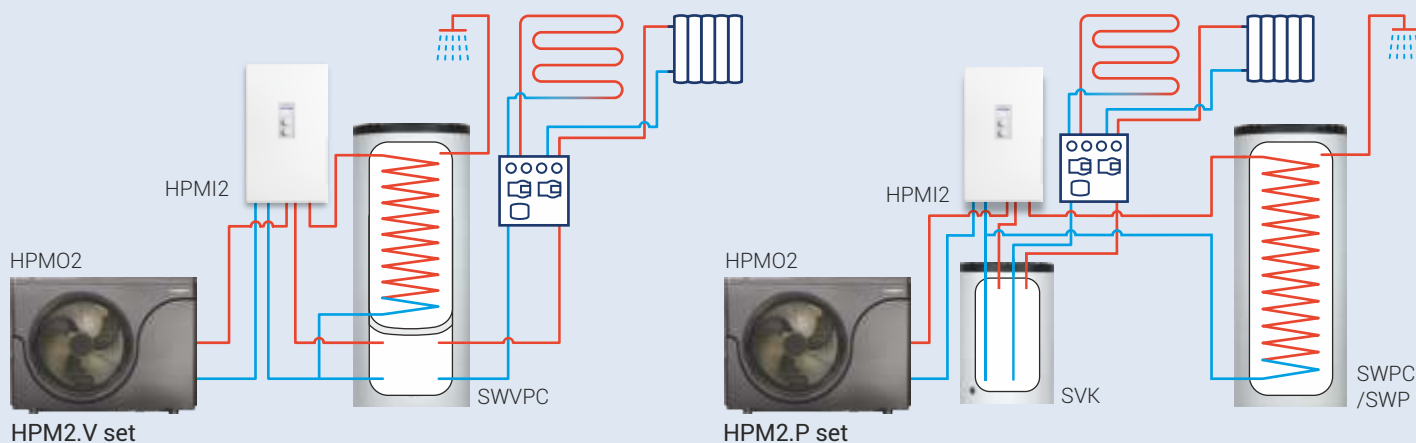

### Sets with HPM02 heat pump and hot water tank and central heating buffer.

	Product code	Description	Set Components
	HPM2.V-8	The set includes: - HPM02-8 monobloc heat pump, - HPMI2-8 indoor unit - Hot water tank/buffer tank SWVPC-250/60 (hot water for 3-5 people) - sensors for outdoor temperature, room temperature, DHW tank, and 2 sensors for heating circuits	HPM02-8 HPMI2-8 SWVPC-250/60 sensor WE-019/05 - 2 pcs. sensor WE-027, sensor WE-033/02 sensor WE-019/01
	HPM2.P-8.1	The set includes: - HPM02-8 monobloc heat pump, - HPMI2-8 indoor unit - hot water heat exchanger. SWP-300 (hot water for 5-7 people) - SVK-100 buffer tank - sensors for outdoor temperature, room temperature, DHW tank and 2 sensors for heating circuits	HPM02-8 HPMI2-8 SVK-100 SWP-300 sensor WE-019/05 - 2 pcs. sensor WE-019/01 sensor WE-027, sensor WE-033/02
	HPM2.V-12	The set includes: - HPM02-8 monobloc heat pump, - HPMI2-8 indoor unit - hot water heat exchanger. SWP-300 (hot water for 5-7 people) - SVK-100 buffer tank - sensors for outdoor temperature, room temperature, DHW tank, and 2 sensors for heating circuits	HPM02-12 HPMI2-12 SWVPC-250/60 sensor WE-019/05 - 2 pcs. sensor WE-027, sensor WE-033/02 sensor WE-019/01
	HPM2.P-12	The set includes: - HPM02-12 monobloc heat pump, - HPMI2-12 indoor unit - hot water heat exchanger. SWP-300 (hot water for 5-7 people) - SVK-100 buffer tank - sensors for outdoor temperature, room temperature, DHW tank, and 2 sensors for heating circuits	HPM02-12 HPMI2-12 SVK-100 SWPC-300 sensor WE-019/05 - 2 pcs. sensor WE-027, sensor WE-033/02 sensor WE-019/01
	HPM2.P-16/23	The set includes: - HPM02-16 monobloc heat pump, - HPMI2-16 indoor unit - hot water heat exchanger. SWP-300 (hot water for 5-7 people) - SVK-100 buffer tank - sensors for outdoor temperature, room temperature, DHW tank, and 2 sensors for heating circuits	HPM02-16/23 HPMI2-16 SVK-100 SWPC-300 sensor WE-019/05 - 2 pcs. sensor WE-027, sensor WE-033/02 sensor WE-019/01

### Heat pump accessories

Product code	Photo	Description
C.MI2		The C.MI2 internet module allows remote control of heat pump operation via the internet using a computer, tablet or smartphone. Control takes place through a dedicated application (Android/iOS) or web browser, providing easy and intuitive operation and use of all advanced features of the device controller
HP.FF		Vibration isolation stand for heat pump 600x190x200 (2 pcs included)
WE-019/01		Temperature sensor for storage tank / buffer tank
WE-019/05		Temperature sensor for heating circuits
HP.HS.24		24V humidity switch to protect against moisture buildup - recommended for building cooling